

غصون النخبة للمصاعد



 056 882 0463

 RQGJ+JP5، المونسية، 13253

 <https://ghoson.sa/>

غصون النخبة للمصاعد



خدماتنا



توريد وتركيب



توريد وتركيب جميع أنواع المصاعد (بانوراما، منزلية، تجارية، شحن) بأحدث التقنيات وأجود الخامات من كبار المصنعين العالميين، مع الالتزام بالمواصفات القياسية السعودية.

صيانة شاملة



برامج صيانة دورية وطارئة شاملة على مدار الساعة لضمان كفاءة تشغيل المصاعد واستدامتها، مع توفير قطع غيار أصلية وفريق فني متخصص.

تحديث وتطوير



تحديث المصاعد القديمة والأنظمة القائمة بأحدث تقنيات التحكم ومكونات الأمان لرفع الأداء وتحسين تجربة المستخدم.

رؤيتنا



أن نكون الخيار الأول والاسم الموثوق في المملكة العربية السعودية لتقديم حلول المصاعد الأكثر تطوراً وأماناً، مع الالتزام العارضة، مع الالتزام التام بمعايير الجودة العالمية والابتكار المستمر لخدمة احتياجات السوق المتنامية.



نبذة عنا



غصون النخبة للمصاعد: مؤسسة وطنية رائدة في الرياض متخصصة في توفير كافة حلول النقل العمودي بأعلى معايير الجودة والأمان. تتميز بفريق عمل خبير ومؤهل يسعى جاهداً لتحقيق رضا العملاء وتلبية احتياجاتهم المتنوعة في أنواع المباني، السكنية والتجارية، من خلال تقديم خدمات متكاملة من التوريد والتركيب إلى الصيانة والتحديث.





غصون النخبة للمصاعد
Ghosoon AlNokhba Elevators

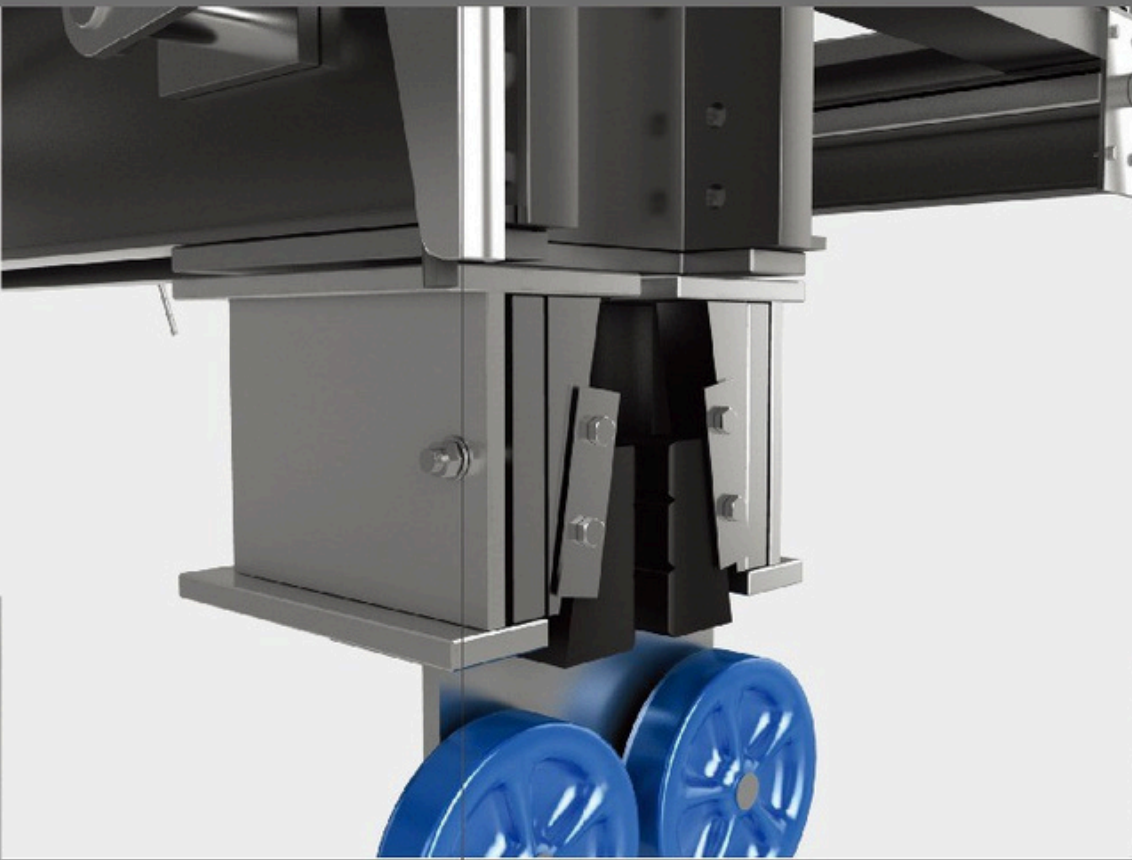
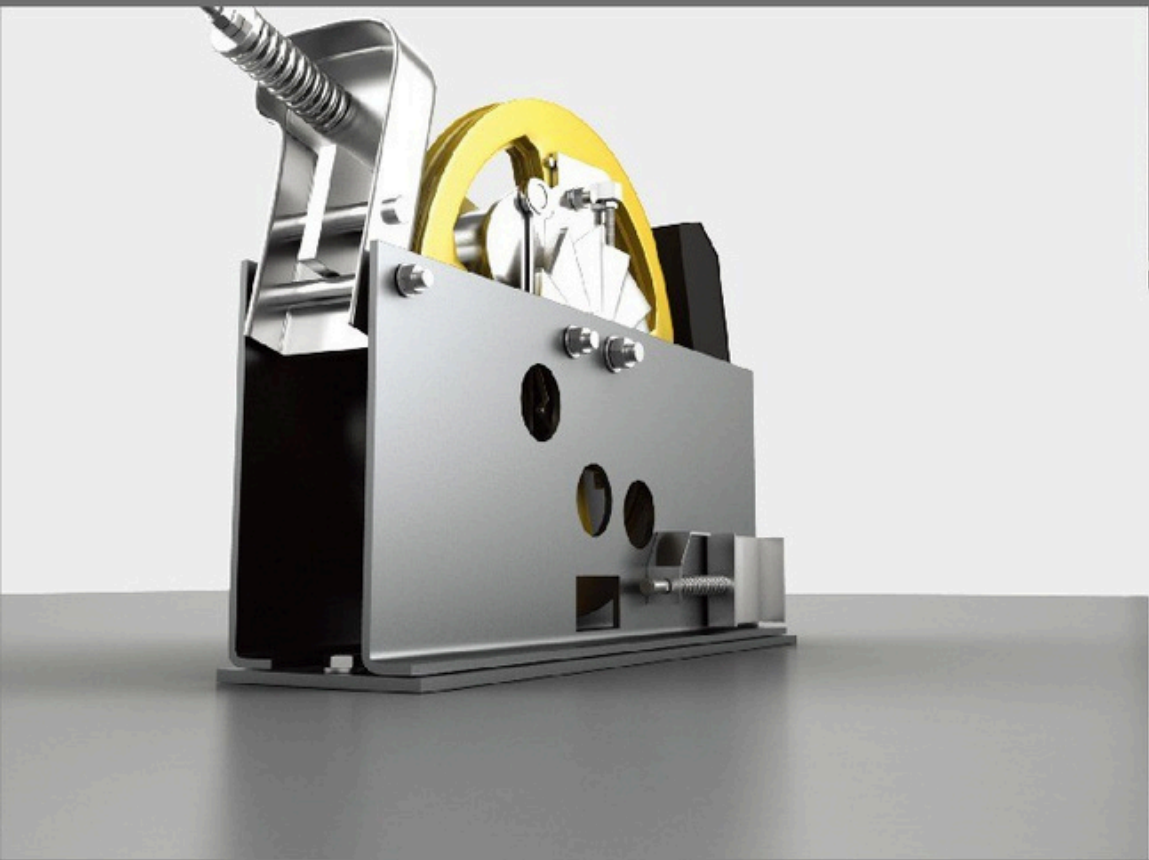

Small machine room elevator

Internal and external repair, quality of construction

Today with the flourishing developments in the construction industry, elevator is indispensable to the buildings. passenger elevator is high quality elevator that integrates the excellent performances and comfortable experience into one. It is your best choice in residence, commercial building, office building, commercial center, hotel, restaurant etc.

Reasonable construction layout

Machine room is exactly the same as the well. It reduces 250mm of machine room height. It pre-leaves a larger building space.

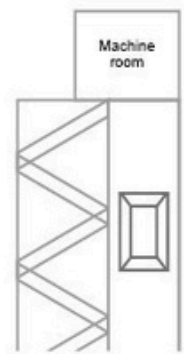

Machine room in machine room elevator

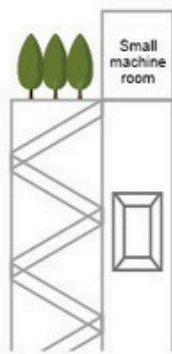

Machine room in small machine room elevator

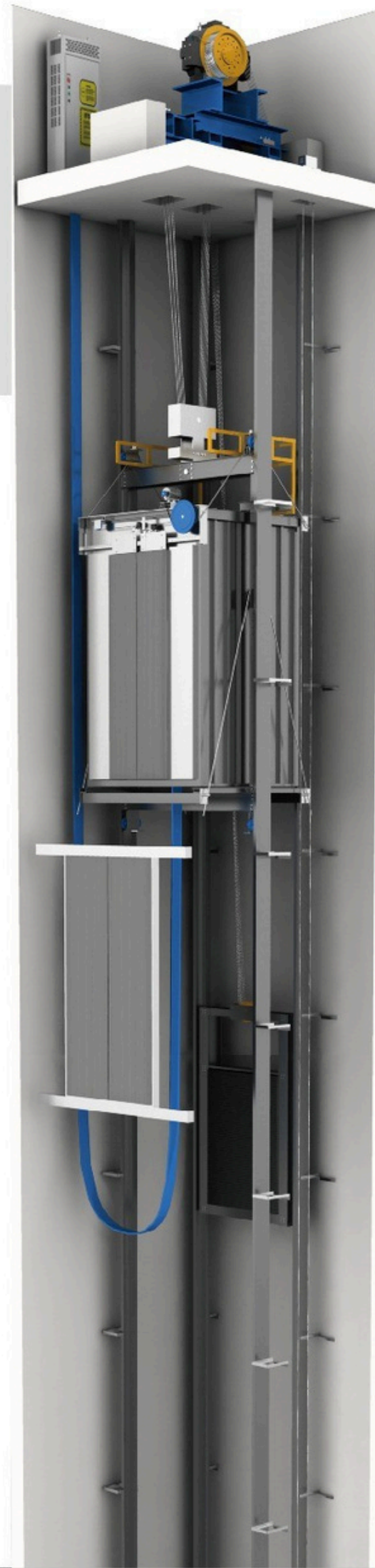

Machine roomless elevator

It easily merges with the building and enhances the building values

With machine room less structure, control cabinet and traction are placed in the shaft flexibly. It saves construction area and with artistic and simple shape, which reduces comprehensive construction cost and leaves design space for architects and developers.

Low energy consumption, space-saving

It is low energy consumption-based. It fully considers building space's utilization rate and cost. Using compact layout and flexible design style and cleverly integrating all kinds of buildings, it is the first choice for modern individualized buildings.

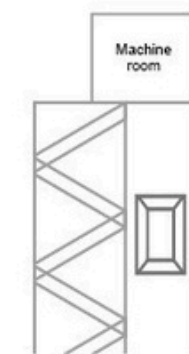

Machine room in machine room elevator

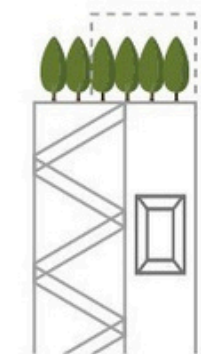

Machine room in machine roomless elevator

أبرز مصنعي ماكينات المصاعد الإيطالية (الجيرلس والجيريوكس)



ساسي Alberto Sassi

الإيطالي الأشهر عالمياً

معروفة بمتانة ماكيناتها
(Gearless & Geared)
وعمرها الافتراضي الطويل.



مدركات متحورة
اللامتراضي الطويل.



مونتاناري Montanari

تنوع ضخم في الموديلات

تناسب كافة الحمولات
والسرعات.



تناسب كافة الحمولات
والممعب والسرعات.



سيكور Sicor

طول تنوع

خياراً
السكنية والتجارية.



خياراً مفضلاً للمشاريع
السكنية والتجارية.



توب جيرز Top Gears

مدركات موفرة للطاقة
ومدمجة

متخصصة في المدركات
لا تحتاج لغرفة محرك.

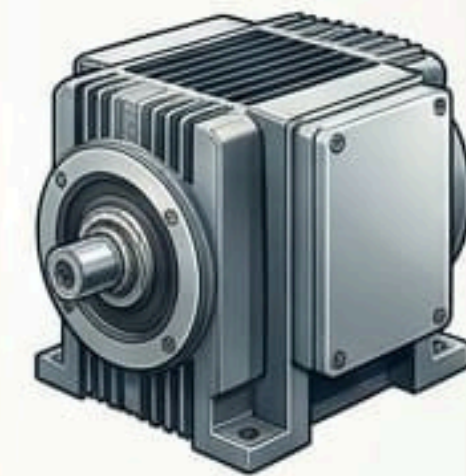

متخصصة في المدركات
التي لا تحتاج لغرفة محرك.



متخصصة في المدركات
لا لا تحتاج لغرفة محرك.



لافيرت Lafert

رائدة في مدركات
المغناطيس الدائم

تتميز بكفاءة عالية جداً
في استهلاك الكهرباء.



تتميز بكفاءة عالية جداً
في استهلاك الكهرباء.





Passenger elevator

Our company the flourishing developments in the construction industry, elevator is indispensable to the buildings. Express passenger elevator is high quality elevator that integrates the excellent performances and comfortable experience into one. It is your best choice in residence, commercial building, office building, commercial center, hotel, restaurant etc. Express passenger elevators are ample in varieties, e.g. passenger elevator with machine room, small machine room elevator, machine room-less elevator, low speed elevator, medium speed elevator, high speed elevator. Express passenger elevators with complete specifications and beautiful decoration satisfy different requirements from various users in all walks of life in an omni-bearing way.

Passenger elevator car decoration



CMCP-001

STANDARD

Ceiling: Hairline stainless steel, LED lights, acrylic dome top

Car wall: Hairline stainless steel

Handrail: None

Floor: PVC(Standard), Marble(Optional)



CMCP-002

OPTIONAL

Ceiling: Mirror stainless steel, acrylic transparent board, LED lights

Car wall: Mirror stainless steel, hairline stainless steel

Handrail: None

Floor: PVC(Standard), Marble(Optional)



CMCP-004

OPTIONAL

Ceiling: Mirror stainless steel, acrylic transparent board, LED lights

Car wall: Mirror etched stainless steel for center plate, auxiliary hairline stainless steel

Handrail: Stainless steel single round tube on both sides

Floor: PVC(Standard), Marble(Optional)

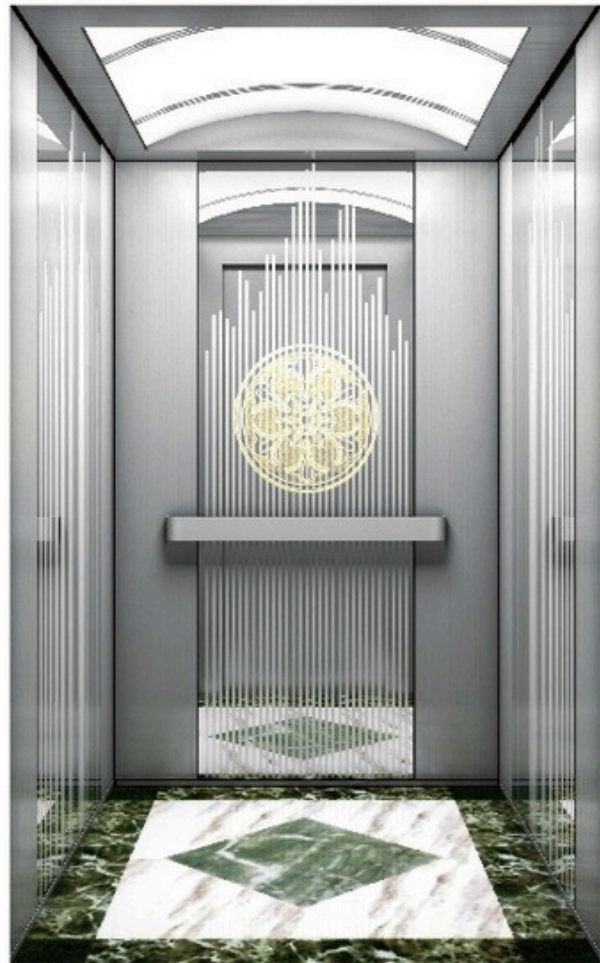

CMCP-003

OPTIONAL

Ceiling: Mirror stainless steel, ached roof, LED lights

Car wall: Mirror etched stainless steel for center plate, titanium etched and hairline stainless steel for the auxiliary plate

Handrail: Stainless steel single flat

Floor: PVC(Standard), Marble(Optional)



CMCP-005

OPTIONAL

Ceiling: Mirror stainless steel, acrylic transparent board, LED lights

Car wall: Mirror etched stainless steel, auxiliary hairline stainless steel

Handrail: Stainless steel single flat

Floor: PVC(Standard), Marble(Optional)



CMCP-018

OPTIONAL

Ceiling: Mirror stainless steel, double arched acrylic plate, LED lights

Car wall: Sprayed steel plate, auxiliary mirror etched stainless steel

Handrail: Stainless steel single round tube

Floor: PVC(Standard), Marble(Optional)



CMCP-020

OPTIONAL

Ceiling: Titanium gold mirror etched stainless steel, acrylic decorative lights

Car wall: Titanium gold mirror stainless steel, etched

Handrail: None

Floor: PVC(Standard), Marble(Optional)



CMCP-019

OPTIONAL

Ceiling: Titanium gold mirror etched stainless steel, acrylic decorative lights, LED lights

Car wall: Titanium gold mirror etched stainless steel, titanium stainless steel and pattern plate

Handrail: None

Floor: PVC(Standard), Marble(Optional)



CMCP-021

OPTIONAL

Ceiling: Steel plate paint frame, surrounded by champagne gold mirror with LED down light

Car wall: Champagne gold mirror, hairline etching pattern combination

Handrail: None

Floor: PVC(Standard), Marble(Optional)

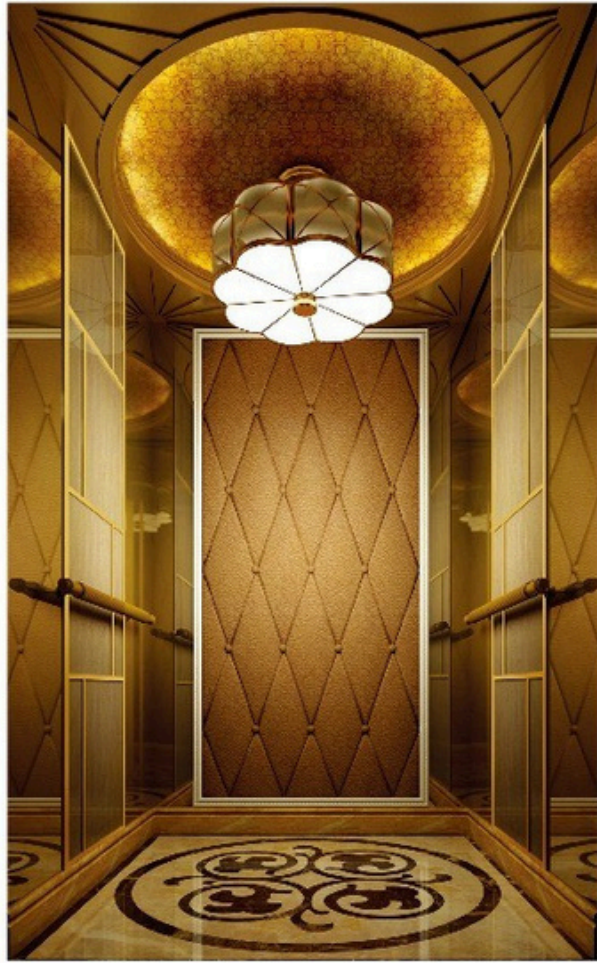

CMCP-034

OPTIONAL

Ceiling: Titanium gold mirror stainless steel
european style ceiling lamp

Car wall: Titanium gold mirror stainless steel, wood
grain trim, leather soft-roll

Handrail: Wood grain round handrail

Floor: PVC(Standard), Marble(Optional)

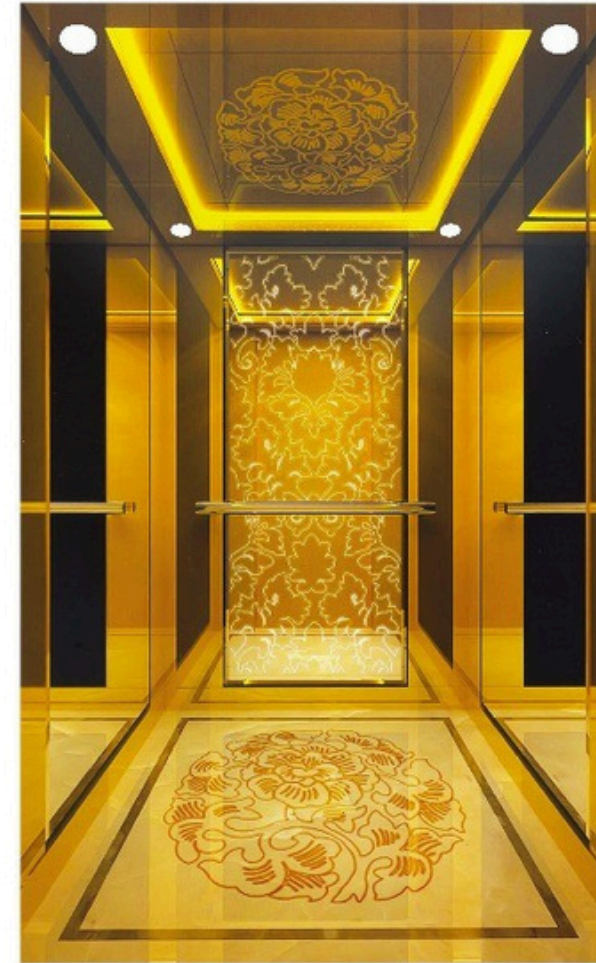

CMCP-036

OPTIONAL

Ceiling: Titanium gold mirror stainless steel, LED
light, mirror etched decorative hidden light
strip

Car wall: Titanium gold mirror stainless steel,
titanium gold mirror etching

Handrail: Titanium gold round handrail

Floor: PVC(Standard), Marble(Optional)

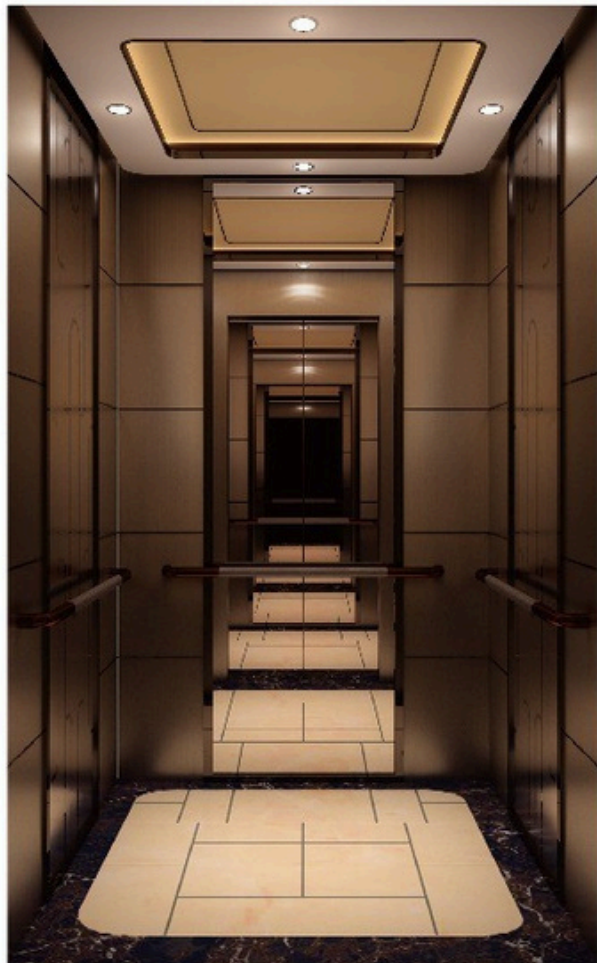

CMCP-035

OPTIONAL

Ceiling: Wood frame, LED downlight

Car wall: Rose gold mirror stainless steel, frosted
etching process

Handrail: Rose gold mirror stainless steel, frosted
etching process round tube handrail

Floor: PVC(Standard), Marble(Optional)

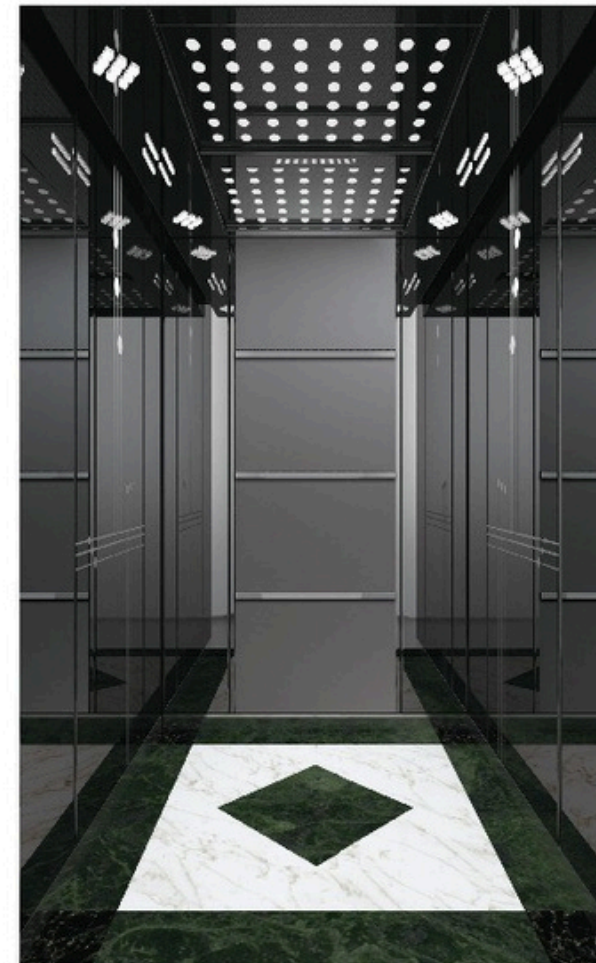

CMCP-037

OPTIONAL

Ceiling: Black titanium mirror, LED lighting

Car wall: Black titanium mirror etched

Handrail: None

Floor: PVC(Standard), Marble(Optional)



CMCP-046

OPTIONAL

Ceiling: Rose gold mirror stainless steel, LED light

Car wall: Wooden, rose gold etching mirror stainless steel, LED light

Handrail: Solid wood decoration, titanium goldstainless steel single round tube on both sides

Floor: PVC(Standard), Marble(Optional)

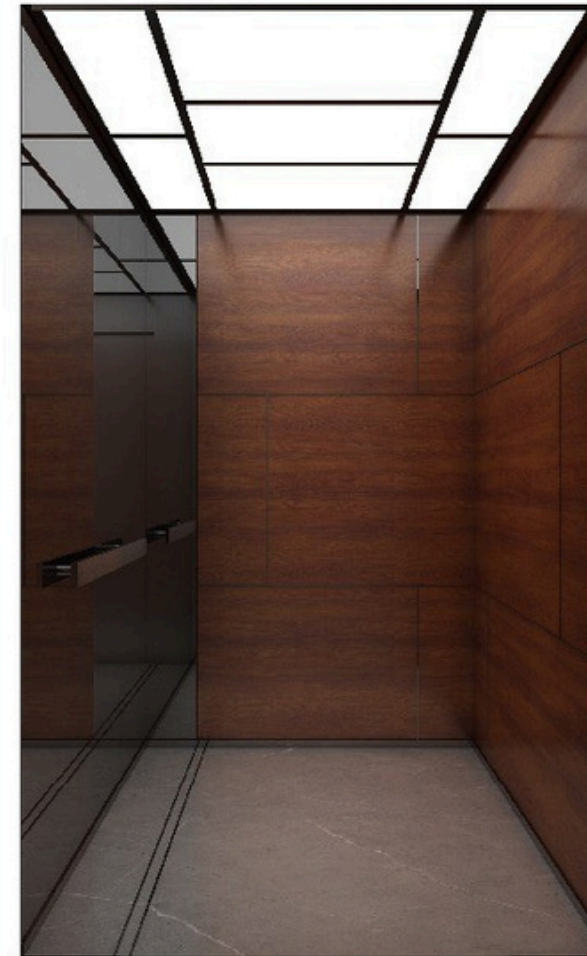

CMCP-048

OPTIONAL

Ceiling: Titanium black stainless steel frame, acrylic light-passing board

Car wall: Wooden, titanium black mirror stainless steel

Handrail: Titanium black mirror stainless steel flat handrail

Floor: PVC(Standard), Marble(Optional)

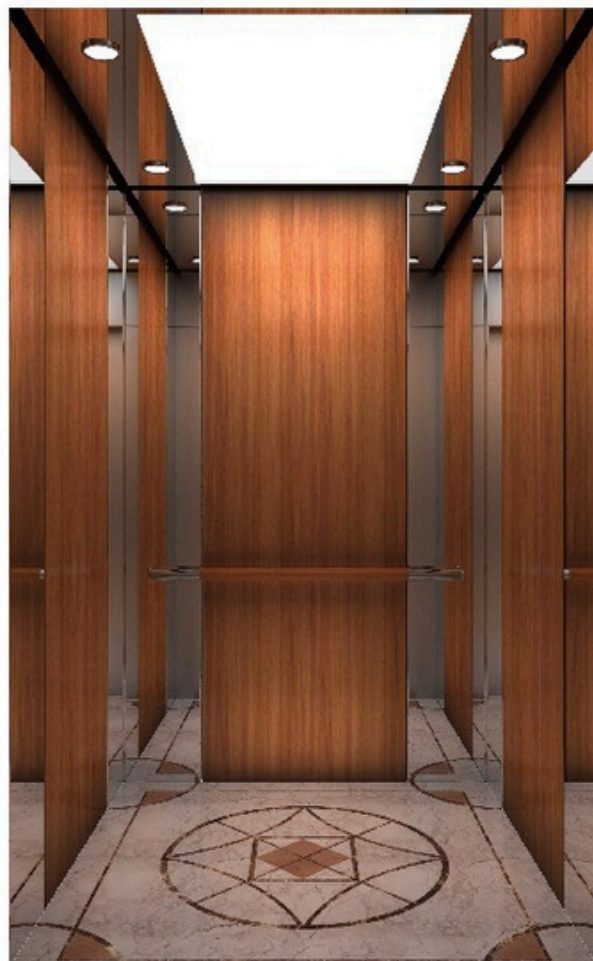

CMCP-047

OPTIONAL

Ceiling: Mirror stainless steel frame, acrylic light-passing board, four sides downlight

Car wall: Wooden, mirror stainless steel

Handrail: Wooden / Mirror stainless steel

Floor: PVC(Standard), Marble(Optional)



CMCP-049

OPTIONAL

Ceiling: Mirror stainless steel frame, acrylic light-passing board

Car wall: Wooden, mirror stainless steel

Handrail: None

Floor: PVC(Standard), Marble(Optional)



CMCP-054

OPTIONAL

Ceiling: Wooden shape, LED lights, light strip

Car wall: Bronze hairline stainless steel, bronze mirror stainless steel, light strip

Handrail: Bronze stainless steel flat handrail

Floor: PVC(Standard), Marble(Optional)



CMCP-056

OPTIONAL

Ceiling: Wooden shape, LED lights

Car wall: Wooden, marble, hidden LED strip

Handrail: Wood grain around

Floor: PVC(Standard), Marble(Optional)



CMCP-055

OPTIONAL

Ceiling: Wooden shape, LED lights

Car wall: Rose gold mirror, wooden, mousse surface

Handrail: None

Floor: PVC(Standard), Marble(Optional)



CMCP-057

OPTIONAL

Ceiling: Mirrored water ripple stainless steel, rose gold stainless steel frame, hidden light strip

Car wall: Leather hard cover, rose gold decorative strip, decorative glass, hidden light strip

Handrail: None

Floor: PVC(Standard), Marble(Optional)

Observation elevator car decoration



360 degree/ circle elevator

Description: Technology advancements go a long way in making our lives better. Pneumatic elevators, for instance, are revolutionising vertical transportation and providing amazing experiences for customers. The unique circular design of these panoramic elevators offers a 360 ° degree view as you travel from floor to floor, making them beautiful additions to any residence. During the ascent or descent, you will enjoy cool, ambient temperatures as a cabin fan circulates the air in the cabin and an LED light keeps the cabin lit.

CO/CON-16

OPTIONAL

Car cover:

Titanium gold stainless steel or titanium gold mirror stainless steel

Observation wall:

Safety laminated glass

Decoration ceiling:

Titanium mirror stainless steel, painted craft board, LED downlight

Car wall:

Safety laminated glass

Handrail:

None

Floor: PVC(Standard),

Marble(Optional)

Color: Black, silver or white powder coating as standard; custom colors available





Hospital elevator

Caring your life Bold

Hospital elevators are not only used to transport passengers, but also have special and strict requirements for the performance due to the special usage. Hospital elevators can run smoothly and comfortably. Creating a quiet, elegant space for the passengers.



- Ceiling: Hairline stainless steel, LED lighting
- Ventilation: Axial fan
- Car wall: Hairline stainless steel
- Handrail: Double flat stainless steel
- Floor: PVC
- Landing door: Hairline stainless steel



Dumbwaiter elevator

Exquisite space for groceries

Dumbwaiter elevator using industrial computer (PLC) or computer control, complete specifications, novel structure, fine workmanship, with safe, reliable stable, easy to operate. The car and landing doors are made by high quality stainless steel plate production lines, luxury and beautiful. It is widely used in hotels, restaurants and other units, it is warmly welcome by users.



Window type (Up and down directly separated)



Ground type (Up and down directly separated)

Operation panel series



CMP-01
(Standard)



CMCB-01
(Standard)



CMCB-01A
(Optional)



CMP-04
(Optional)



CMP-02
(Optional)



CMCB-02
(Optional)

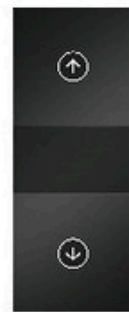

CMCB-02B
(Optional)



CMP-05
(Optional)
Disable person COP

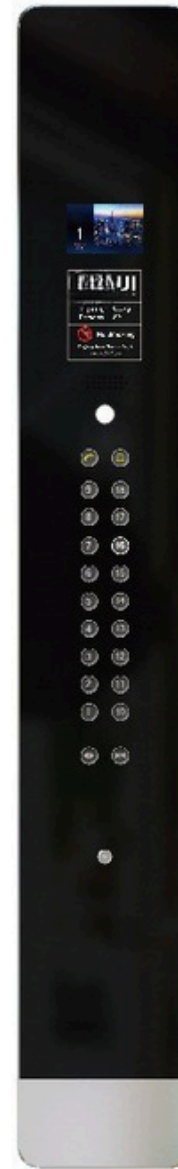

CMP-03
(Optional)



CMCB-03
(Optional)

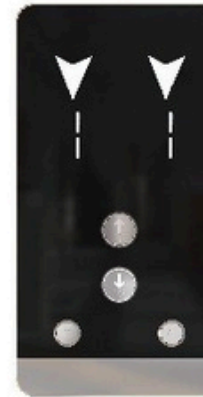

CMCB-03A
(Optional)

CMP-06
Optional
Integrated operation panel



Whole series of
card reader



Fingerprint sensor



IC access card

Optional button



AN-01



AN-02



AN-03



AN-04



AN-05



AN-11



AN-06



AN-07



AN-08



AN-09



AN-10

Horizontal display



CMZH-01
(Optional)



CMZH-02
(Optional)



CMZH-03
(Optional)

Optional display screen



CMD-01
7 inch display
(Optional)



CMD-02
8 inch display
(Optional)



CMD-03
10 inch display
(Optional)

CMP-06
Optional
Integrated operation panel



Whole series of
card reader



Fingerprint sensor



IC access card

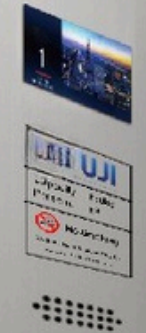

Operation panel series

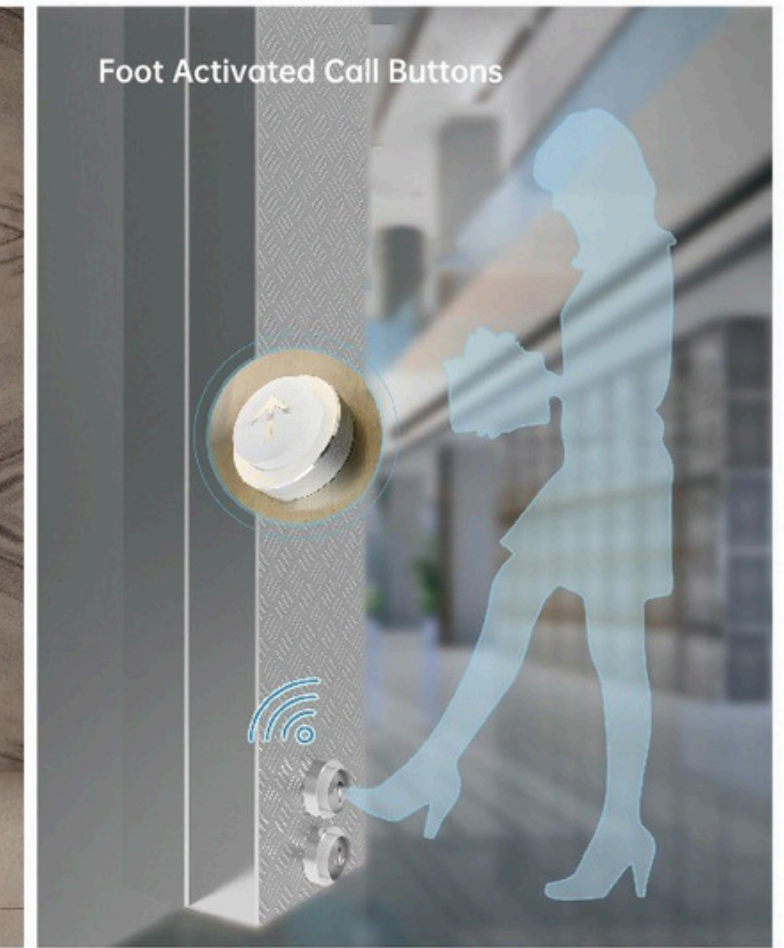

Arrival Light series

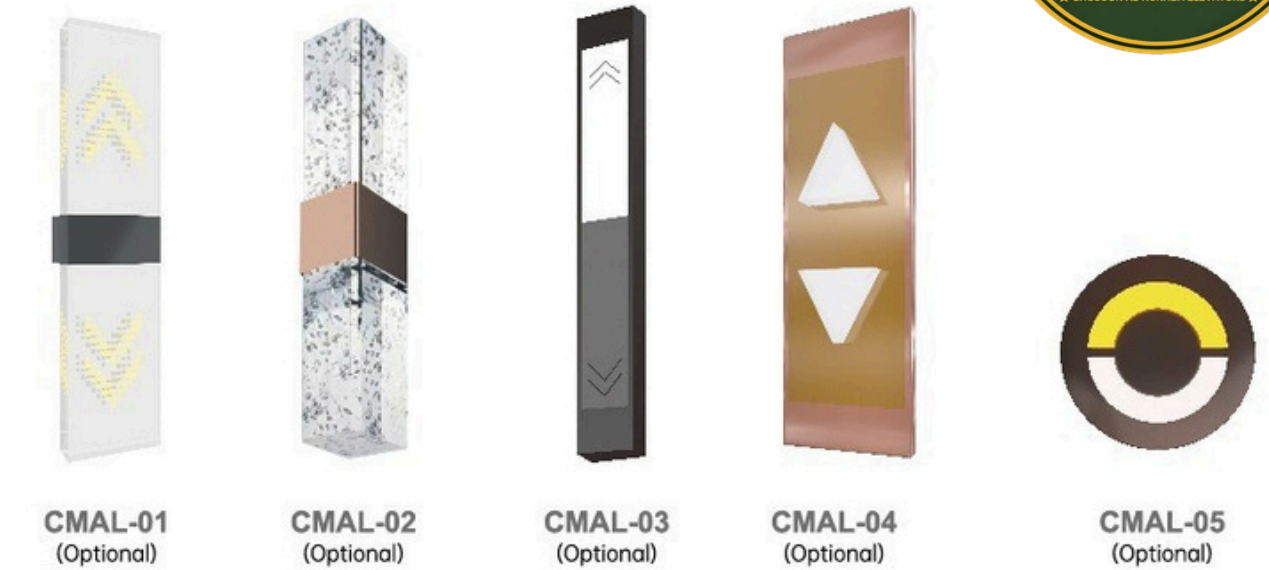

Landing door series



CMLD-001 Standard **CMLD-002** Optional **CMLD-003** Optional
 Hairline stainless steel Stainless steel, glass Mirror, etched and hairline



CMLD-007 Optional **CMLD-008** Optional **CMLD-009** Optional
 Mirror, etched Mirror, etched Mirror, etched



CMLD-004 Optional **CMLD-005** Optional **CMLD-006** Optional
 Mirror, etched Mirror, etched Mirror, etched



CMLD-010 Optional **CMLD-011** Optional **CMLD-012** Optional
 Mirror, etched Mirror, etched Black titanium, mirror and etched

Note: The decoration requirements (material, color) of the ceiling of the car hall door can be customized according to your own needs, which is almost the meaning.

Landing door series



CMLD-025 Optional **CMLD-026** Optional **CMLD-027** Optional
 Titanium, mirror and etched Titanium, mirror and etched Titanium, mirror and etched



CMLD-031 Optional **CMLD-032** Optional **CMLD-033** Optional
 Titanium, mirror, etching, hairline Titanium, mirror, etching Mirror, etching, champagne gold



CMLD-028 Optional **CMLD-029** Optional **CMLD-030** Optional
 Titanium, mirror and etched Rose, mirror and etched Titanium, stainless steel and glass



CMLD-034 Optional **CMLD-035** Optional **CMLD-036** Optional
 Mirror, etching, champagne gold Mirror, etching, champagne gold Rose, mirror, etching

Landing door series



CMLD-037 Optional **CMLD-038** Optional **CMLD-039** Optional
 Rose,mirror,etching Rose,mirror,etching Rose,mirror,etching



CMLD-040 Optional **CMLD-041** Optional **CMLD-042** Optional
 Black titanium,mirror,etching Black titanium,mirror,etching Dark black titanium,hairline stainless steel



Handrail series



Ceiling series



CMC-01 Optional



CMC-06 Optional



CMC-11 Optional



CMC-16 Optional

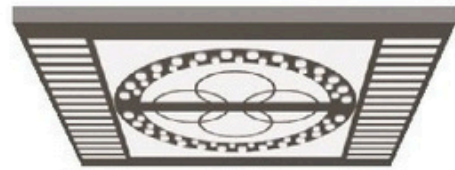

CMC-02 Optional



CMC-07 Optional



CMC-12 Optional



CMC-17 Optional

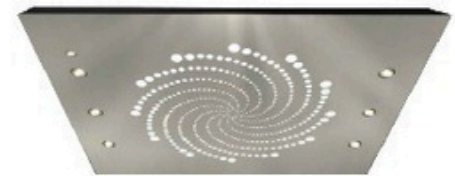

CMC-03 Optional



CMC-08 Optional



CMC-13 Optional



CMC-18 Optional

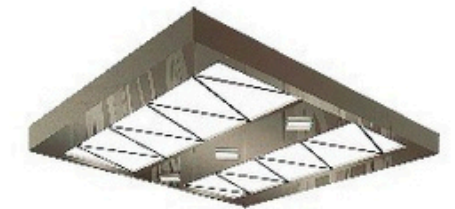

CMC-04 Optional



CMC-09 Optional



CMC-14 Optional



CMC-19 Optional

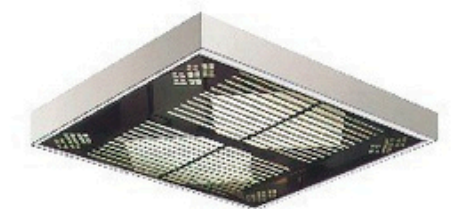

CMC-05 Optional



CMC-10 Optional



CMC-15 Optional



CMC-20 Optional

Floor series

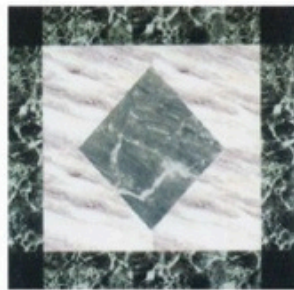

CMF-01
Optional



CMF-02
Optional

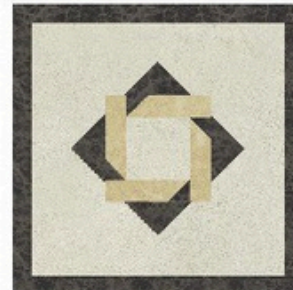

CMF-03
Optional

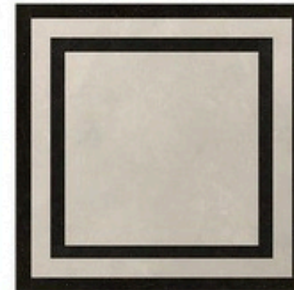

CMF-04
Optional

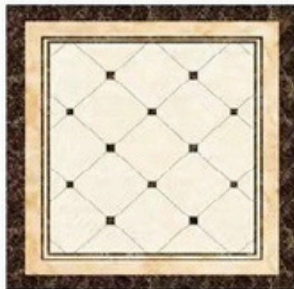

CMF-05
Optional



CMF-06
Optional



CMF-07
Optional

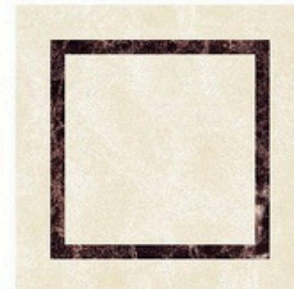

CMF-08
Optional



CMF-09
Optional

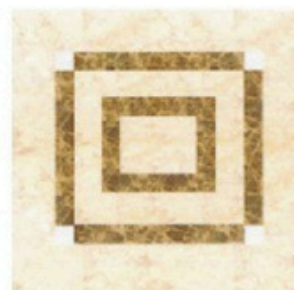

CMF-10
Optional

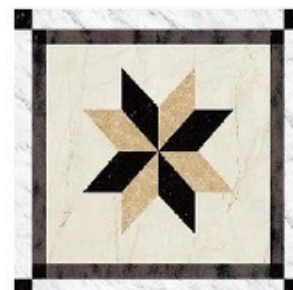

CMF-11
Optional



CMF-12
Optional



CMF-13
Optional



CMF-14
Optional



CMF-15
Optional



CMF-16
Optional

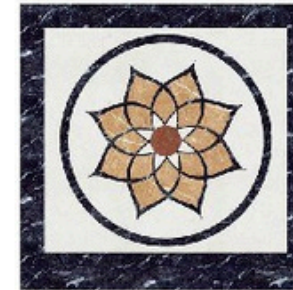

CMF-17
Optional



CMF-18
Optional



CMF-19
Optional

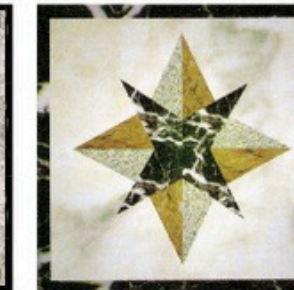

CMF-20
Optional



CMF-21
Optional



CMF-22
Optional



CMF-23
Optional



CMF-24
Optional



CMF-25
Optional



CMF-26
Optional



CMF-27
Optional



CMF-28
Optional



CMF-29
Optional



CMF-30
Optional



CMF-31
Optional



CMF-32
Optional



CMF-33
Optional



CMF-34
Optional

Small machine room passenger elevator construction sketch

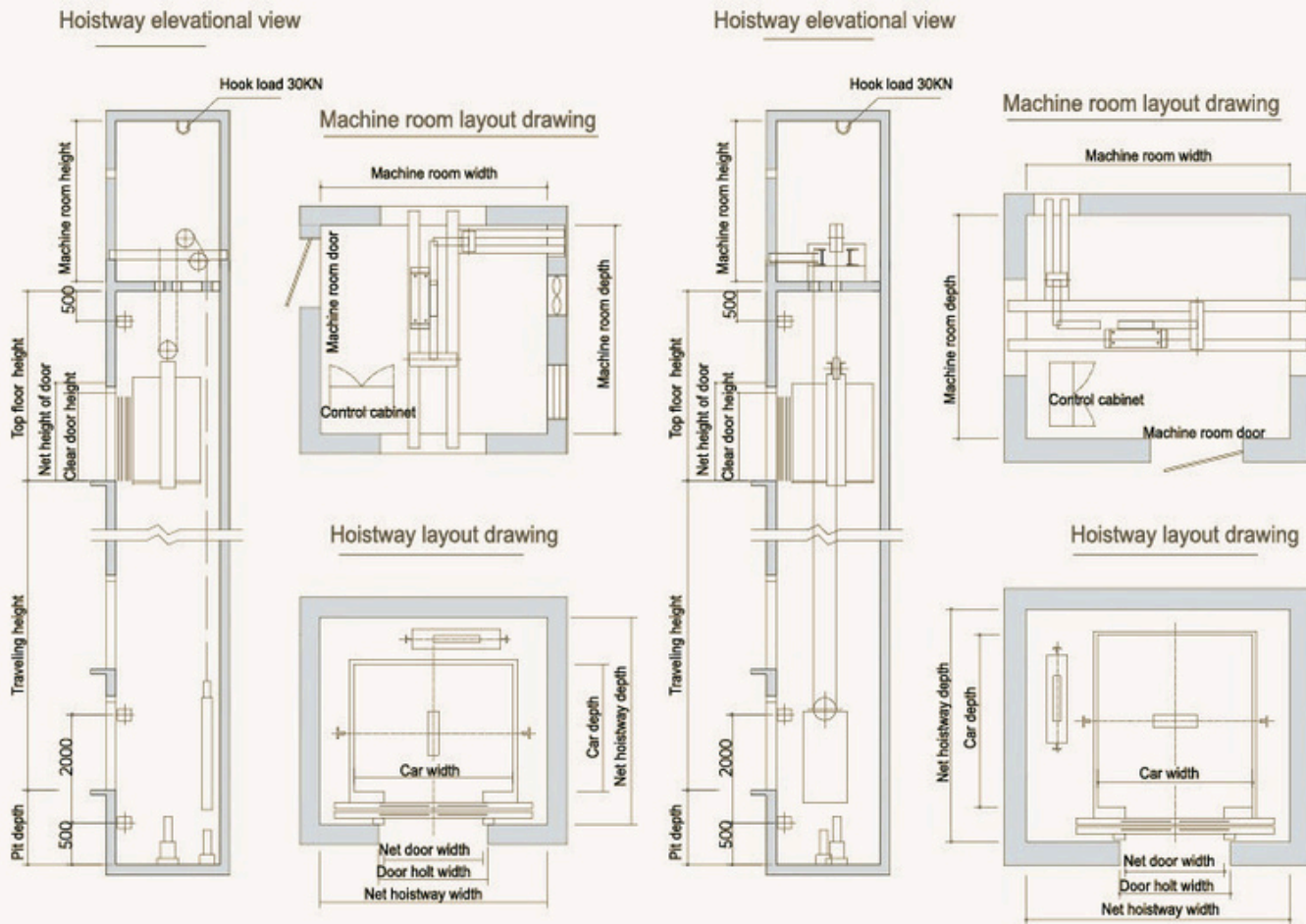

MRL passenger elevator construction sketch

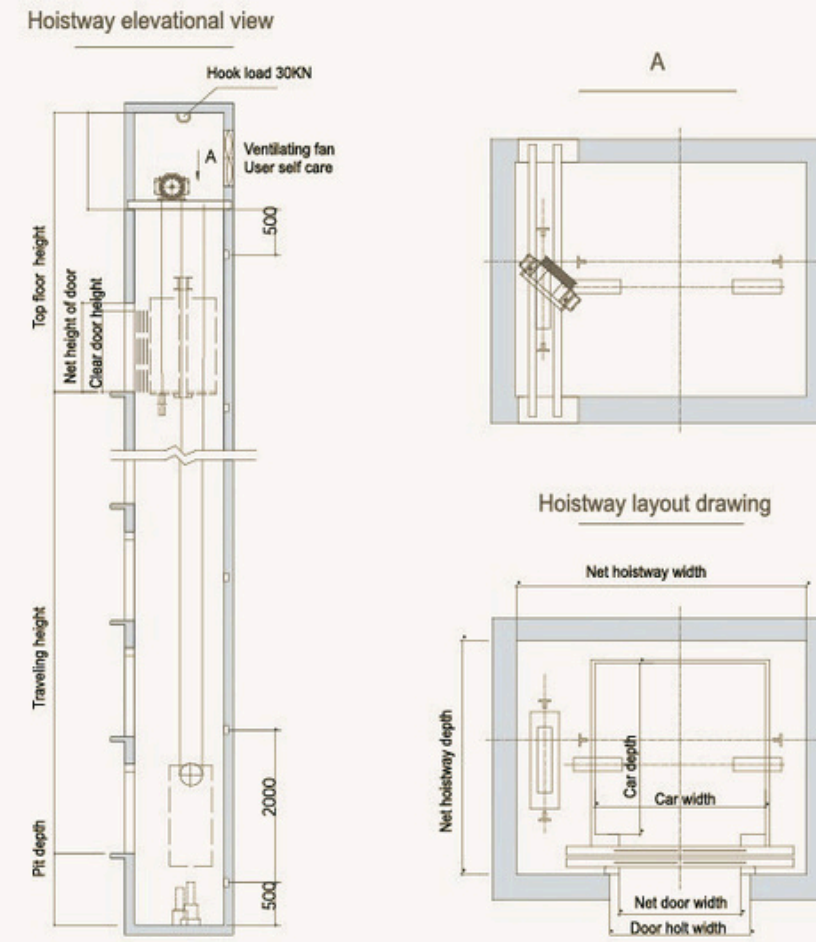

Model	Load (KG)	Passenger	Speed (m/s)	Net size of car CW×CD×CH(mm)	Net door opening size OP×OPH(mm)	Net hoistway size HW×HD(mm)	Machine room size MRW×MRD×MRH(mm)	Pit depth (mm)	Overhead height OH
AL100	450KG	6P	1.0	1100×1100×2400	700×2100	1800×1800	1800×1800×2200	1400	4200
			1.5					1500	4600
AL100	630KG	8P	1.0	1400×1100×2400	800×2100	2000×1850	2000×1850×2200	1400	4200
			1.5-1.75					1700	4500
			2.0					1400	4200
AL100	800KG	10P	1.0	1400×1350×2400	800×2100	2000×2100	2000×2100×2400	1700	4500
			1.5-1.75					1800	4800
			2.0					2200	5200
			2.5					1400	4200
			3.0					1700	4500
AL100	1000KG	13P	1.0	1600×1400×2400	900×2100	2200×2200	2200×2200×2400	1800	4800
			1.5-1.75					2200	5200
			2.0					2800	5800
			2.5					1400	4200
			3.0					1700	4500
AL100	1150KG	15P	1.0	1900×1400×2400	1000×2100	2300×2200	2300×2200×2400	1800	4800
			1.5-1.75					2200	5200
			2.0					2800	5800
			2.5					1400	4200
			3.0					1700	4500
AL100	1250KG	16P	1.0	1900×1500×2400	1100×2100	2400×2200	2400×2200×2400	1800	4800
			1.5-1.75					2200	5200
			2.0					2800	5800
			2.5					1400	4200
			3.0					1700	4500
AL100	1350KG	18P	1.0	1900×1600×2400	1100×2100	2600×2200	2600×2200×2400	1800	4800
			1.5-1.75					2200	5200
			2.0					2800	5800
			2.5					1400	4200
			3.0					1700	4500
AL100	1600KG	21P	1.0	2000×1750×2400	1200×2100	2600×2450	2600×2450×2500	1400	4200
			1.5-1.75					1700	4500
			2.0					1800	4800
			2.5					2200	5200
			3.0					2800	5800
AL100	2000KG	26P	1.0	2000×2100×2400	1200×2200	2600×2900	2600×2900×2600	1400	4200
			1.5-1.75					1700	4500
			2.0					1800	4800
			2.5					2200	5200
			3.0					2800	5800

Model	Load (KG)	Passenger	Speed (m/s)	Net size of car CW×CD×CH(mm)	Net door opening size OP×OPH(mm)	Net hoistway size HW×HD(mm)	Pit depth (mm)	Overhead height OH
ALN180	450KG	6P	1.0	1100×1100×2400	700×2100	1800×1500	1500	4200
			1.5-1.75				1500	4500
			2.0				2000	5000
			2.5				2500	5500
			3.0				1500	4200
ALN180	630KG	8P	1.0	1100×1400×2400	800×2100	1800×1800	1500	4200
			1.5-1.75				1500	4500
			2.0				2000	5000
			2.5				2500	5500
			3.0				1500	4200
ALN180	800KG	10P	1.0	1400×1350×2400	800×2100	2300×2000	1500	4200
			1.5-1.75				1500	4500
			2.0				2000	5000
			2.5				2500	5500
			3.0				1500	4200
ALN180	1000KG	13P	1.0	1600×1400×2400	900×2100	2500×2000	1500	4200
			1.5-1.75				1500	4500
			2.0				2000	5000
			2.5				2500	5500
			3.0				1500	4200
ALN180	1150KG	15P	1.0	1900×1400×2400	1000×2100	2800×2000	1500	4300
			1.5-1.75				1500	4600
			2.0				2000	5000
			2.5				2500	5500
			3.0				1500	4300
ALN180	1250KG	16P	1.0	1900×1500×2400	1100×2100	2900×2000	1500	4300
			1.5-1.75				1500	4600
			2.0				2000	5000
			2.5				2500	5500
			3.0				1500	4300
ALN180	1350KG	18P	1.0	1900×1600×2400	1100×2100	2900×2400	1500	4300
			1.5-1.75				1500	4600
			2.0				2000	5000
			2.5				2500	5500
			3.0				1500	4300
ALN180	1600KG	21P	1.0	2000×1750×2400	1200×2100	3000×2400	1500	4300
			1.5-1.75				1500	4600
			2.0				2000	5000
			2.5				2500	5500
			3.0				1500	4300
ALN180	2000KG	26P	1.0	2000×2100×2400	1200×2200	3400×2900	1500	4300
			1.5-1.75				1500	4600
			2.0				2000	5000
			2.5				2500	5500
			3.0				1500	4300

MR observation elevator construction sketch

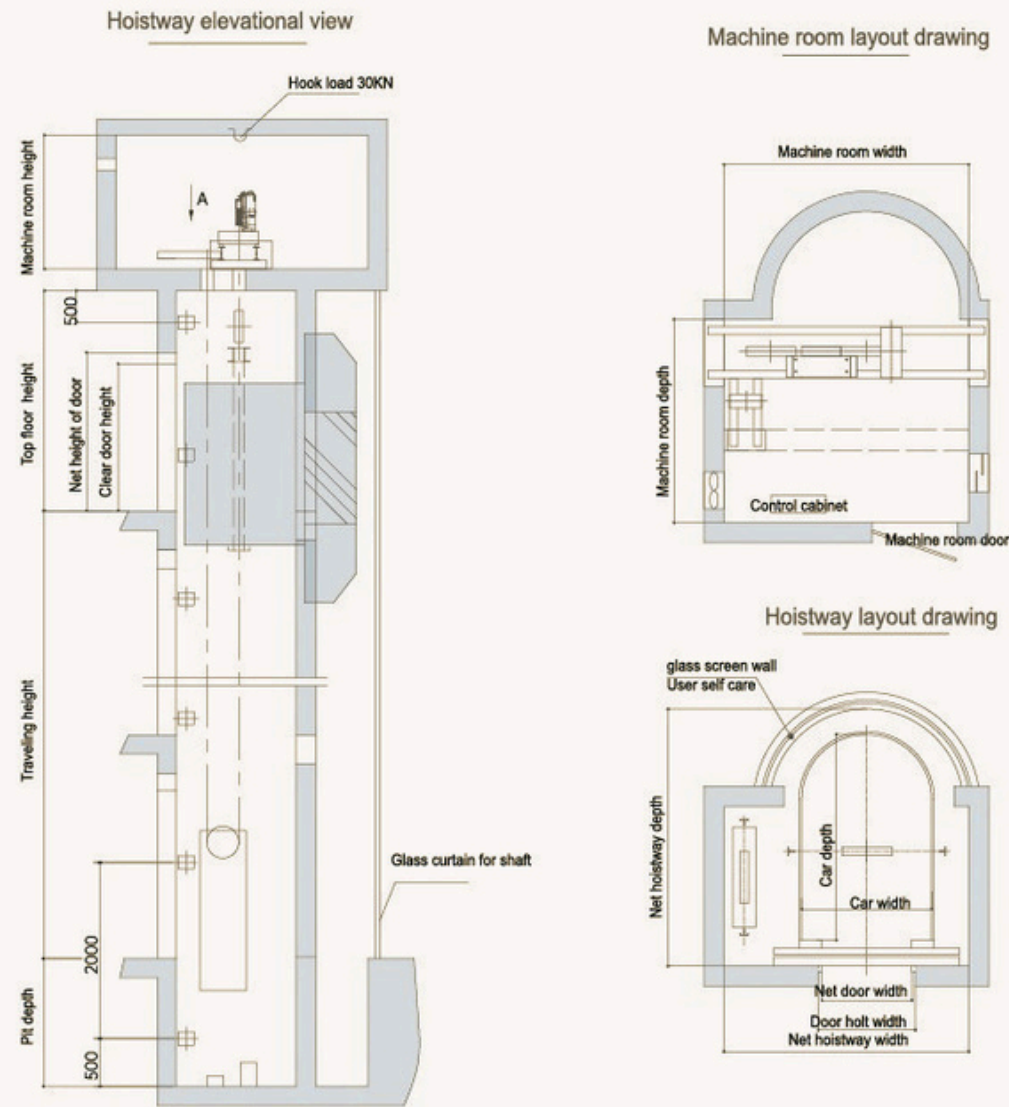

MRL observation elevator construction sketch

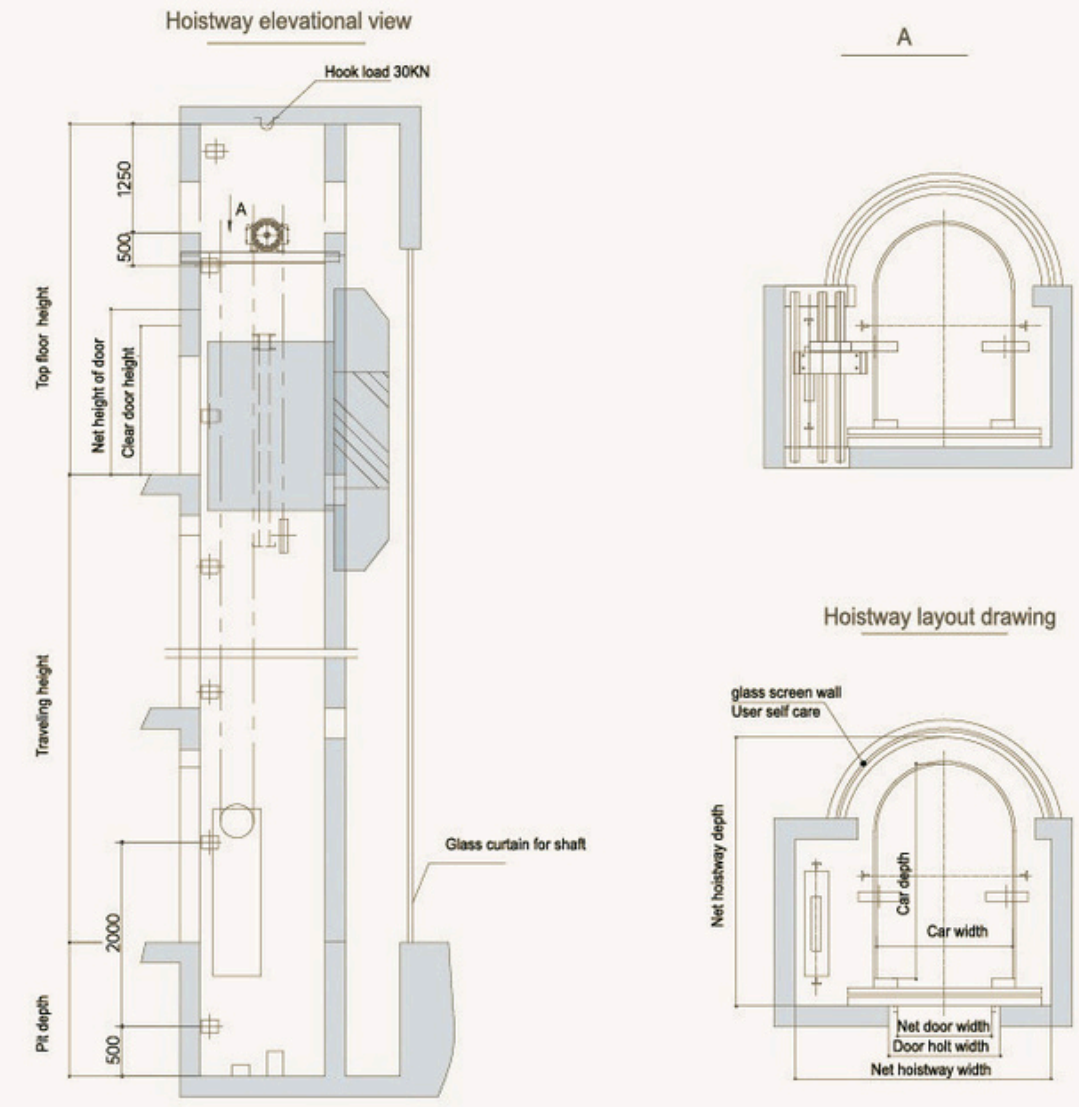

Model	Load (KG)	Passenger	Speed (m/s)	Net size of car CW×CD×CH(mm)	Net door opening size OP×OPH(mm)	Net hoistway size HW×HD(mm)	Machine room size MRW×MRD×MRH(mm)	Pit depth (mm)	Overhead height OH
AL200	450KG	6P	1.0	1100×1300×2400	700×2100	1900×1900	1900×1900×2200	1500	4500
			1.5-1.75						
AL200	630KG	8P	1.0	1200×1600×2400	800×2100	2000×2200	2000×2200×2200	1800	5000
			1.5-1.75						
AL200	800KG	10P	1.0	1400×1600×2400	800×2100	2200×2200	2200×2200×2400	2000	5000
			1.5-1.75						
			2.0-2.5						
AL200	1000KG	13P	1.0	1400×1800×2400	900×2100	2200×2400	2200×2400×2400	2000	5000
			1.5-1.75						
			2.0-2.5						
AL200	1150KG	15P	1.0	1400×2000×2400	900×2100	2200×2600	2200×2600×2400	2000	5000
			1.5-1.75						
			2.0-2.5						
AL200	1250KG	16P	1.0	1500×2000×2400	1000×2100	2300×2650	2300×2650×2400	2000	5000
			1.5-1.75						
			2.0-2.5						
AL200	1350KG	18P	1.0	1600×2100×2400	1100×2100	2400×2750	2400×2750×2400	2200	5000
			1.5-1.75						
			2.0-2.5						
AL200	1600KG	21P	1.0	1600×2300×2400	1100×2100	2500×2950	2500×2950×2400	2300	5000
			1.5-1.75						
			2.0-2.5						
AL200	2000KG	26P	1.0	1800×2500×2400	1200×2100	2800×3150	2800×3150×2400	2300	5000
			1.5-1.75						
			2.0-2.5						

Model	Load (KG)	Passenger	Speed (m/s)	Net size of car CW×CD×CH(mm)	Net door opening size OP×OPH(mm)	Net hoistway size HW×HD(mm)	Pit depth (mm)	Overhead height OH
ALN220	450KG	6P	1.0	1100×1300×2400	700×2100	1950×1900	1500	4500
			1.5-1.75					
ALN220	630KG	8P	1.0	1200×1600×2400	800×2100	2300×2200	1800	4500
			1.5-1.75				1800	4800
			2.0-2.5				1800	4500
ALN220	800KG	10P	1.0	1400×1600×2400	800×2100	2400×2200	1800	4800
			1.5-1.75				2800	5800
			2.0-2.5				1800	4500
ALN220	1000KG	13P	1.0	1400×1800×2400	900×2100	2450×2400	1800	4800
			1.5-1.75				2800	5800
			2.0-2.5				1800	4500
ALN220	1150KG	15P	1.0	1400×2000×2400	900×2100	2450×2600	1800	4800
			1.5-1.75				2800	5800
			2.0-2.5				1800	4500
ALN220	1250KG	16P	1.0	1500×2000×2400	1000×2100	2600×2650	1800	4600
			1.5-1.75				1800	4900
			2.0-2.5				2800	5800
ALN220	1350KG	18P	1.0	1600×2200×2400	1100×2100	2700×2850	1800	4600
			1.5-1.75				1800	5100
			2.0-2.5				2800	5800
ALN220	1600KG	21P	1.0	1600×2300×2400	1100×2100	2700×2650	1800	4600
			1.5-1.75				1800	5100
			2.0-2.5				2800	5800
ALN220	2000KG	23P	1.0	1800×2500×2400	1200×2100	2900×3150	1800	4600
			1.5-1.75				1800	5100
			2.0-2.5				2800	5800

MR freight elevator construction sketch

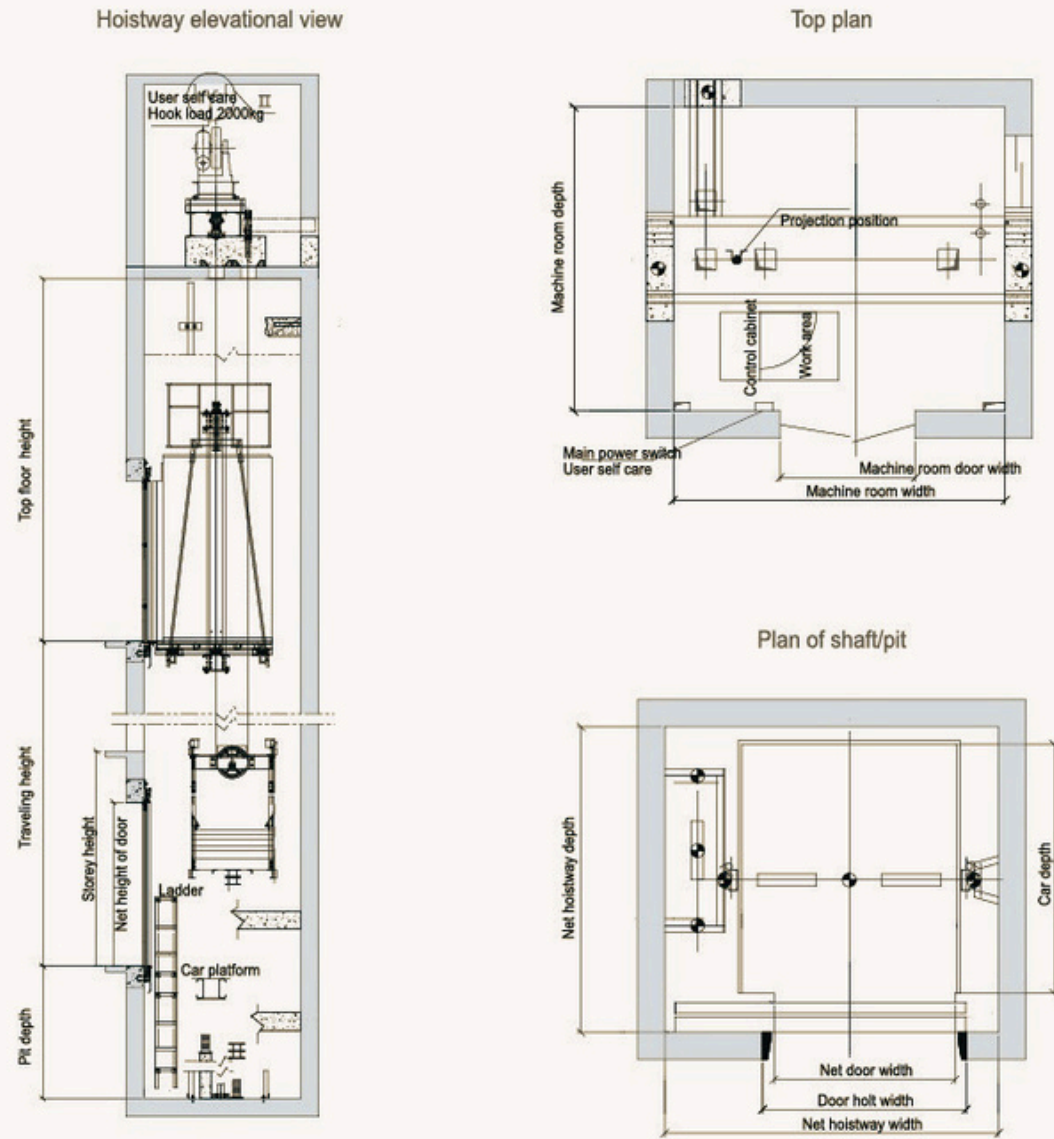

MRL freight elevator construction sketch

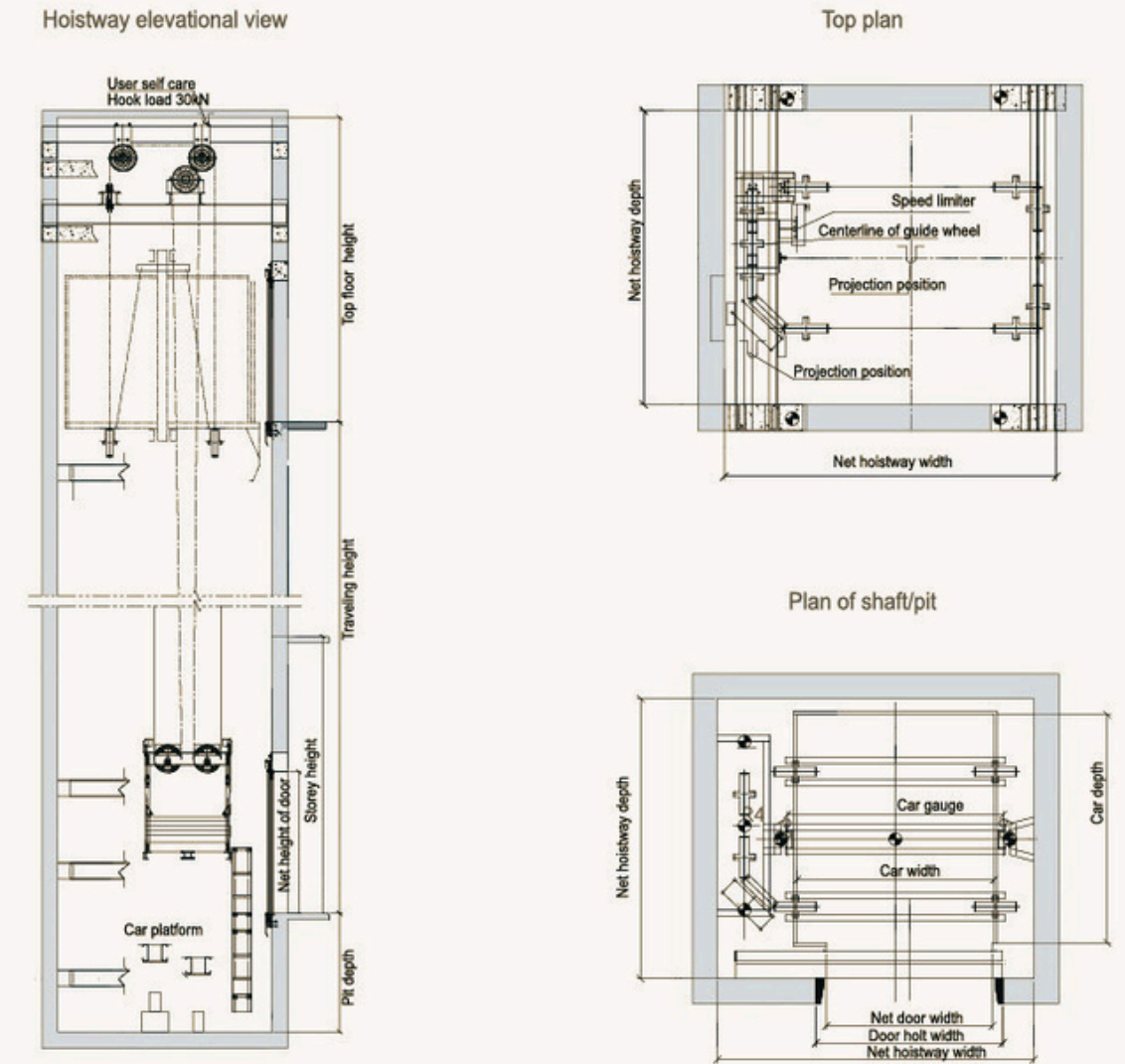

Model	Load (KG)	Speed (m/s)	Net size of car CW×CD×CH(mm)	Net door opening size OP×OPH(mm)	Net hoistway size HW×HD(mm)	Machine room size MRW×MRD×MRH(mm)	Pit depth (mm)	Overhead height OH
AL300	1600KG	0.5	1600×2200×2200	1300×2100	2500×2700	2500×2700×2500	1400	4200
		1.0						
AL300	2000KG	0.5	1600×2600×2200	1300×2100	2500×3200	2500×3200×2500	1400	4200
		1.0	1900×2200×2200	1500×2100	2800×2700	2800×2700×2500		
AL300	3000KG	0.5	2200×2700×2200	1800×2100	3300×3200	3300×3200×2500	1700	4500
		1.0						
AL300	4000KG	0.5	2400×3000×2200	1900×2100	3800×3500	3850×3850×2600	1700	4800
		1.0						
AL300	5000KG	0.25	2400×3600×2300	2000×2200	3800×4200	3800×4200×2600	1700	4500
		0.5	2800×3200×2500	2400×2400	4200×3700	4200×3700×2600		
AL300	8000KG	0.25/0.5	3000×4500×2500	2600×2400	4500×5000	4500×5000×3000	1800	5200
AL300	10000KG	0.25/0.5	3400×4500×2500	2600×2400	5000×5600	5000×5600×3000	1800	5500

Model	Load (KG)	Speed (m/s)	Net size of car CW×CD×CH(mm)	Net door opening size OP×OPH(mm)	Net hoistway size HW×HD(mm)	Pit depth (mm)	Overhead height OH
ALN330	1600KG	0.5	1300×2000×2200	1000×2100	3000×2800	1700	4500
		1.0					
ALN330	2000KG	0.5	1900×2200×2200	1500×2100	3300×2800	1700	4500
		1.0					
ALN330	3000KG	0.5	2200×2700×2200	1800×2100	3700×3200	1700	4800
		1.0					
ALN330	4000KG	0.5	2200×3250×2200	1900×2100	3850×3850	1700	5200
ALN330	5000KG	0.25	2400×3600×2500	2000×2400	4100×4100	1800	5500
		0.5					

MR hospital elevator construction sketch

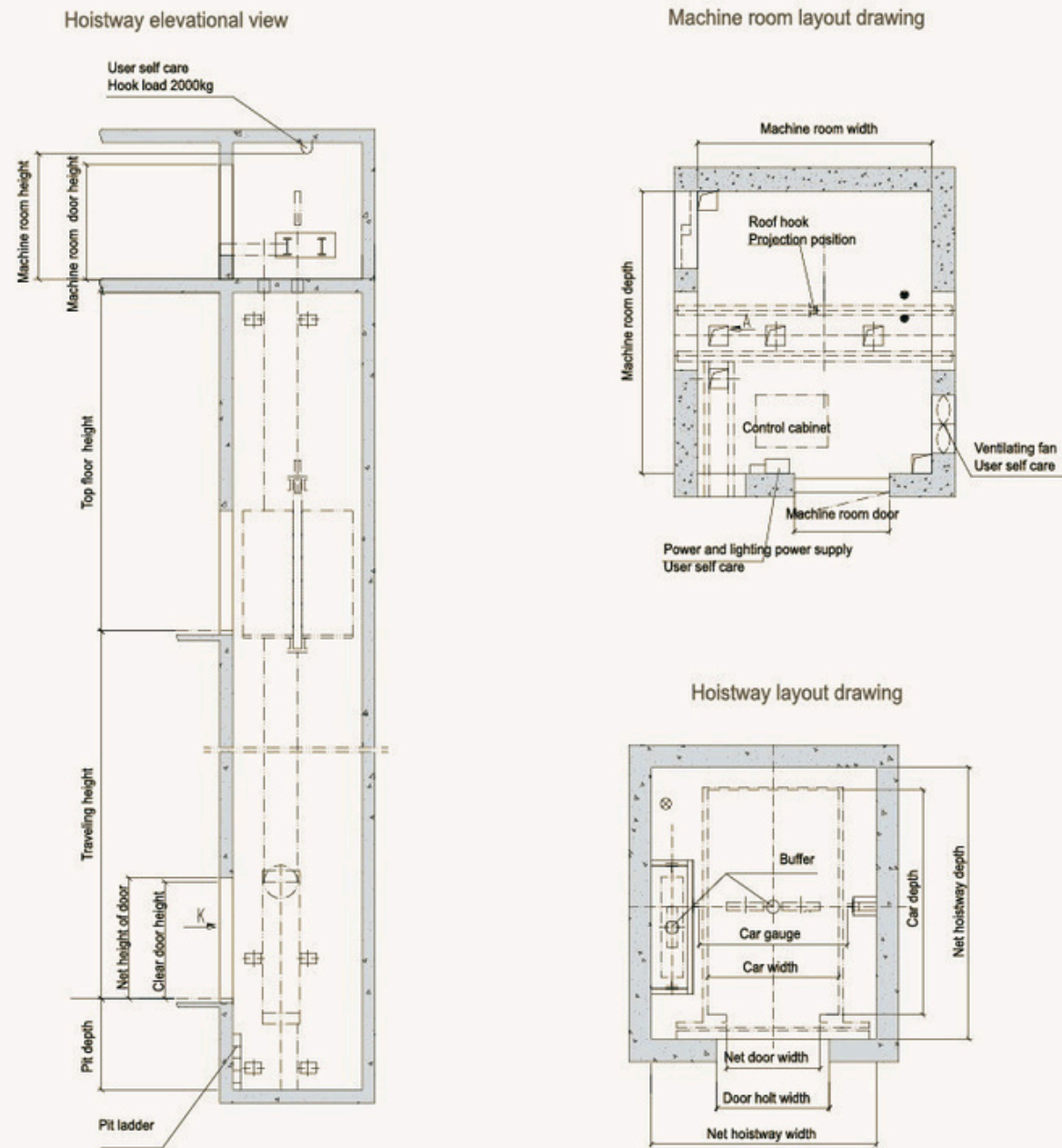

MRL hospital elevator construction sketch

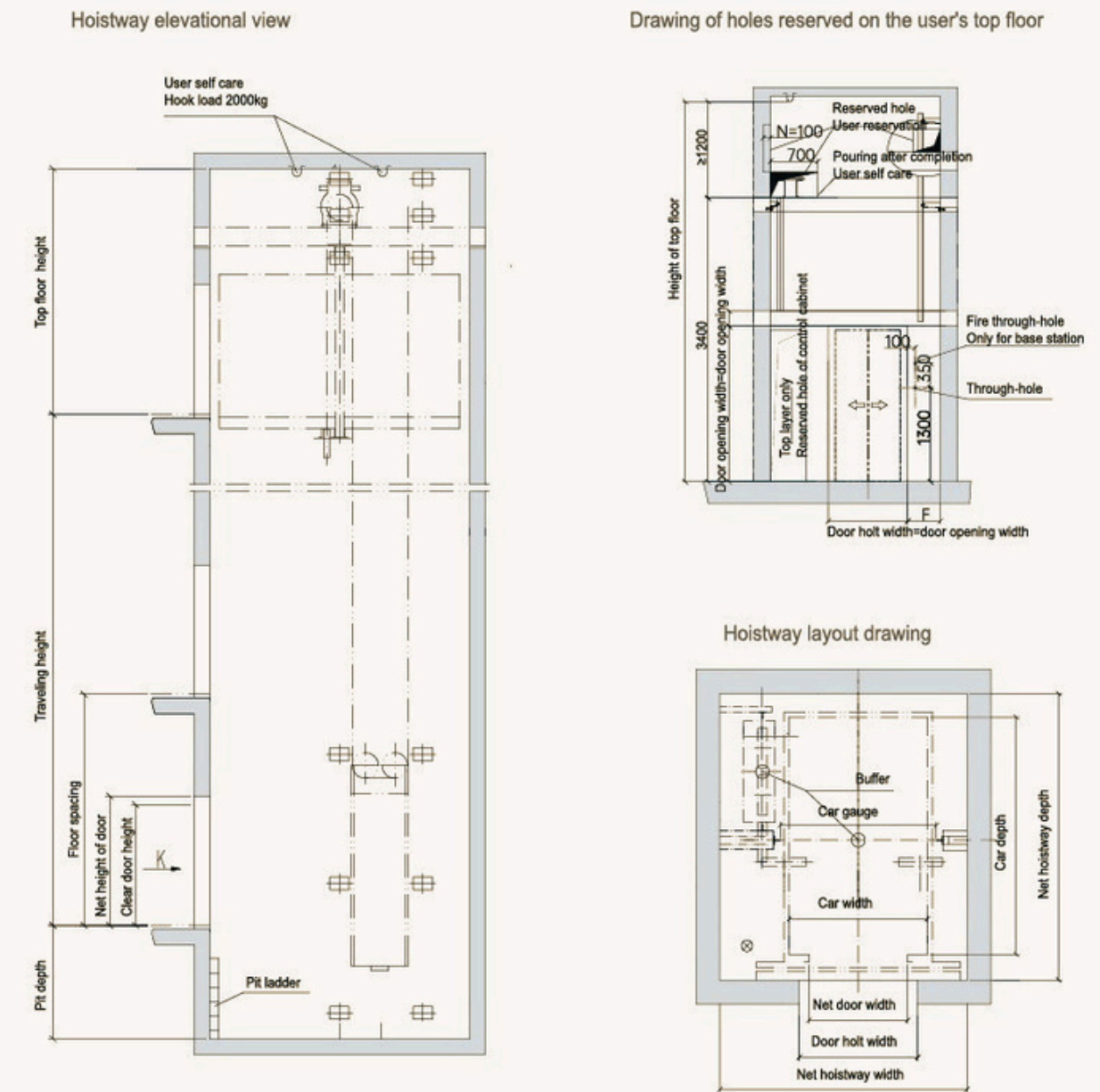

Model	Load (KG)	Passenger	Speed (m/s)	Net size of car CW×CD×CH(mm)	Net door opening size OP×OPH(mm)	Net hoistway size HW×HD(mm)	Machine room size MRW×MRD×MRH(mm)	Pit depth (mm)	Overhead height OH
AL500	1600KG	21P	1.0	1400×2400×2400	1200×2100	2300×2850	2300×2850×2500	1500	4400
			1.5-1.75					1700	4500
			2.0					1800	4600
AL500	2000KG	26P	1.0	1600×2550×2400	1300×2100	2600×3000	2600×3000×2600	1500	4400
			1.5-1.75					1700	4500
			2.0					1800	4600

Model	Load (KG)	Passenger	Speed (m/s)	Net size of car CW×CD×CH(mm)	Net door opening size OP×OPH(mm)	Net hoistway size HW×HD(mm)	Pit depth (mm)	Overhead height OH	
ALN550	1600KG	21P	1.0	1400×2400×2400	1200×2100	2550×2850	1600	4500	
			1.5-1.75					1800	4800
			2.0					2000	5000
ALN550	2000KG	26P	1.0	1600×2600×2400	1300×2100	2750×3050	1600	4500	
			1.5-1.75					1800	4800
			2.0					2000	5000



شهادة السجل التجاري

مؤسسة غصون النخبة للمصاعد

الرقم الوطني الموحد: 7053328089

تاريخ الإصدار: 11/01/2026

نوع الكيان: مؤسسة

حالة السجل: نشط

البيانات الأساسية للسجل التجاري



7053328089



رخصة نشاط تجاري Commercial Activity Licence مؤسسة غصون النخبة للمصاعد

License Expiry Date تاريخ نهاية الترخيص 1448/10/13 License Number رقم الرخصة الموحد 470923046852

Owner's Name اسم المالك مؤسسه غصون النخبة للمصاعد

Owner's ID رقم هوية المالك 7053328089

ISIC Classification التصنيف الصناعي القياسي الدولي (نشاط ايزك) تركيب وصيانة المصاعد

Detailed Activity النشاط التفصيلي تركيب وصيانة المصاعد

Sub-Municipality البلدية قطاع شرق مدينة الرياض

Municipality الأمانة أمانة منطقة الرياض

Street الشارع البلقاء

District الحي المونسية

Sign's Area مساحة اللوحة 3 Sign's Type نوع اللوحة إرشادية



Shop's Total Area مساحة المحل الإجمالية 44 متر مربع

للاطلاع على الأنشطة الإضافية وتفصيل الرخصة يرجى مسح رمز الاستجابة السريع Code QR

Permit Expiry Date تاريخ انتهاء التصريح Permit Number رقم التصريح Permits التصاريح

هذا الترخيص لا يخلو البدء بالانتاج الا بعد الحصول على تراخيص الجهات ذات العلاقة



مركز العناية بالعملاء
199040

Balady_cs



saudimomra



www.balady.gov.sa



سلامة
Salamah



ترخيص الدفاع المدني مؤسسة غصون النخبة للمصاعد

تاريخ الإنتهاء
١٤٤٨-١٠-١٣



تاريخ الإصدار
١٤٤٧-١٠-١٠



رقم الترخيص
١-٠٠٢١٤٢٦٢٦-٤٧



بيانات المنشأة

التصنيف الرئيسي للمنشأة (نشاط الايزك)

٤٣٢٩١١ - تركيب وصيانة المصاعد

نوع المنشأة	اسم النشاط التجاري	المساحة الاجمالية	عدد الادوار
مكتب	مؤسسة غصون النخبة للمصاعد	٤٤	١

بيانات المستأجر / المالك

اسم المستأجر / المالك	رقم المنشأة	رقم السجل التجاري
مؤسسة غصون النخبة للمصاعد	٧٠٥٣٣٢٨٠٨٩	٧٠٥٣٣٢٨٠٨٩

بيانات العنوان

المنطقة	المدينة / المحافظة	الحي	الشارع
منطقة الرياض	الرياض	المونسية	البلقاء

بيانات الدفاع المدني

جهة اصدار الترخيص
مركز السلامة الميدانية بغرناطة



موقع المحل

للاطلاع على الانشطة الاضافية وتفاصيل الترخيص يرجى مسح رمز الاستجابة السريع QR Code أعلى الصفحة

هذه الوثيقة موقعة ومصدقة إلكترونياً ولا تحتاج توقيع يدوي وفقاً لقرار مجلس الوزراء رقم (٨) وتاريخ ٧/٠٣/١٤٢٨ هـ المنظم للتعاملات الإلكترونية. وللتأكد من صحة الرخصة يرجى زيارة موقع المديرية العامة للدفاع المدني على الرابط التالي (www.998.gov.sa) وإدخال رقم الرخصة المذكور أعلاه - الإدارة العامة لتقنية المعلومات



920000356



@saudidcd



www.salamah.998.gov.sa



TIN 3145530944 الرقم المميز
Certificate No. 100261169897460 رقم الشهادة
Certificate date 14/01/2026 تاريخ الشهادة



هيئة الزكاة والضريبة والجمارك
Zakat, Tax and Customs Authority

المملكة العربية السعودية
Kingdom of Saudi Arabia

شهادة تسجيل في ضريبة القيمة المضافة VAT Registration Certificate

تشهد هيئة الزكاة والضريبة والجمارك بأن المكلف أدناه مسجل في ضريبة القيمة المضافة بتاريخ 2026/02/01م

The Zakat, Tax and Customs Authority certifies that the taxpayer below is VAT registered on 01/02/2026 AD

Taxpayer Name	مؤسسة عصون النخبة للمصاعد	اسم المكلف
VAT Registration Number	314553094400003	رقم التسجيل الضريبي
Effective Registration Date	2026/02/01	تاريخ نفاذ التسجيل
Taxpayer Address	الرياض، المونسية، البلقاء، 13253	عنوان المكلف
CR National Number / License/ Contract / ID No.	7053328089	الرقم الموحد للسجل التجاري / الرخصة / العقد / الهوية
Tax Period	ربع سنوي-Quarterly	الفترة الضريبية
First Filing due date	2026/04/30	تاريخ استحقاق أول إقرار ضريبي

ملاحظة: كمكلفين مسجلين في ضريبة القيمة المضافة، لا يجوز لكم تحصيل ضريبة القيمة المضافة من عملائكم قبل تاريخ نفاذ التسجيل في الضريبة. و في حال تبين غير ذلك ستقوم هيئة الزكاة والضريبة و الجمارك بتنفيذ الغرامات المستحقة

Note: As a VAT registered taxpayer, you are not allowed to collect VAT from your customers prior to the effective date of the tax registration. If otherwise approved, The ZAKAT, Tax and Customs Authority will impose the applicable penalties.



zatca.gov.sa

19993

@zatca_sa



هذه الوثيقة مستخرجة من النظام الآلي ولا تحتاج إلى توقيع
و لا يعتد بهذه الشهادة إلا بعد التحقق من موقع الهيئة
www.zatca.gov.sa

Proof Number 1084476894
Original Date 21/4/2026
Expiration Date 18/10/2026

رقم الإثبات
تاريخ الإصدار
تاريخ الانتهاء

العنوان الوطني
NATIONAL ADDRESS



إثبات عنوان Address Proof

Address Holder Details

بيانات صاحب العنوان

Name: ghusun alnukhbah Establishment For elevators الاسم: مؤسسة غصون النخبة للمصاعد
Customer Acc.: 3 1 3 3 4 5 0 6 6 9 0 رقم الحساب
Reg. Date: 21/4/2026 تاريخ التسجيل

Address Details

تفاصيل العنوان

Short Address: R U M H 3 4 3 3 العنوان المختصر
Building No.: 3 4 3 3 رقم المبنى
Street: Al Balqa الشارع: البلقاء
Secondary No.: 7 2 4 1 الرقم الفرعي
District: Al Munisiyah Dist. الحي: حي المونسية
Postal Code: 1 3 2 5 3 الرمز البريدي
City: RIYADH المدينة: الرياض
Kingdom of Saudi Arabia المملكة العربية السعودية



للتحقق To Verify

<https://proof.address.gov.sa/VerifyProofNA.aspx>

تم إصدار هذا الإثبات إلكترونياً ولا يتطلب التوقيع عليه

تم إصدار هذا الإثبات بناءً على طلب الموضح أعلاه، ويحظر قطعياً تقليده أو إدخال أي تعديلات عليه سواءً بالإضافة أو الحذف، ويعد الإثبات لاغياً إذا شابه شيء من ذلك، كما يعرض صاحبه للمساءلة القانونية.

This proof has been issued electronically and does not require a signature

This proof has been issued upon the request of the above-named, and it is absolutely prohibited to imitate it or make any modifications to it, whether by addition or deletion, and the proof is considered void if it is marred by something, and its owner is subject to legal accountability.



نشكركم لثقتكم
بغصون النخبة
اختياركم الأمثل للمصاعد

Thank you for choosing
Ghoson Al-Nukhba
Your Premier Elevator Partner

تواصل معنا

الهاتف: 056 882 0463

العنوان: RQGJ+JP5، المونسية، الرياض 13253

Contact Us

Phone: 056 882 0463

Address: RQGJ+JP5, Al Munsiyah, Riyadh 13253

<https://ghoson.sa/>